

CONTENTS

1. INSTRUCTION	1
2. SPECIFICATIONS	1
3. USER GUIDE	2
3.1 Panel Description	2
3.1.1 Front Panel	2
3.1.2 RearPanel	3
3.2 Operation Instruction	3
3.2.1 Front Panel Operation Instruction	3
3.2.2 Operation Instruction	4
4. ATTENTION	6
5. MAINTENANCE	7
6. ACCESSORIES	7

1、 Introduction

This programmable dc power, has a wide voltage and current work scope, higher precision, with constant pressure and constant flow model, provides the output or internal switch, and has the preset parameters 16 groups, convenient and quick.

- ◆ Two independent adjustable output 0-32 V / 0-3 A
- ◆ Fixed output can switch over all the way for 2.5 V / 3.3 V / 5 V / 3 A
- ◆ Four groups LED display: four display
- ◆ Minimum resolution: 10 mV, 1 mA
- ◆ Digital panel
- ◆ Digital potentiometer thick adjustable/fine tuning function, low noise, long life
- ◆ Key lock function
- ◆ Output ON/OFF function
- ◆ Parallel simultaneous tracking, highest voltage up to 64 V, up to 2 times the maximum current single rated current
- ◆ Have the software function calibration
- ◆ This product is very light.very small and it has beautiful shape

2、 Technology parameters

Data / Type		PPS2320A	
output		CH1&CH2	CH3
	Voltage	0-32V	2.5V/3.3V/5V
	Current	3A	0-3A
constant Voltage	effect	Source effect: $\leq 0.01\%+3mV$ Load effect: $\leq 0.01\%+3mV(\text{Setting current} \leq 3A)$; $\leq 0.02\%+5mV(\text{Setting current} >3A)$	
	Grain bobo and noise	$\leq 5mV_{rms}(5Hz-1MHz)$	
	Reaction time	Rise time: $\leq 100ms$ (no load to full load)	fall time : $\leq 100mS$ (full load)
	Output range	0 to 3 2V Output voltage range set can be adjusted continuously	
Constant current	effect	Source effect: $\leq 0.2\%+3mA$ Load effect: $\leq 0.2\%+3mA$	

	ripple	$\leq 3\text{mArms}$
	Output range	0 to the max output current can be adjusted continuously
	parallel	Source effect: $\leq 0.01\%+3\text{mV}$ Tracking error: $\leq 0.5\%\pm 30\text{mV}$ Load effect: $\leq 0.01\%+5\text{mV}$ (Setting current $\leq 3\text{A}$) $\leq 0.02\%+5\text{mV}$ (Setting current $>3\text{A}$)
	series	Source effect: $\leq 0.01\%+5\text{mV}$ Tracking error: $\leq 0.5\%\pm 30\text{mV}$
display	display	4 digital display, red/ green
	resolution	Voltage: $10\text{mV}(0-32.00\text{V})$ Current: 1mA (0-3.000A) (Less than 10mA current shows are for reference only)
	Programming precision (25 \pm 5V)	Voltage: $\leq \pm$ (Read value 0.5%+2 位) Current: $\leq \pm$ (Read value 0.5%+2 位)
	Read accuracy (25 \pm 5V)	Voltage: $\leq \pm$ (Read value 0.5%+2 位) Current: $\leq \pm$ (Read value 0.5%+3 位)
CH3	Output voltage	2.5V/3.3V/5V $\pm 5\%$ (A key type switch, avoid effectively switch noise, prolong life read values)
	Output Current	3A
	effect	Source effect: $\leq 5\text{mV}$ Load effect $\leq 40\text{mV}$
	Ripple and the noise	$\leq 5\text{mVrms}$
function	Panel lock	yes
	Storage/out of	16 group
other	power	AC100V/120V/220V/240V $\pm 10\%$, 50/60Hz
	size	340(l)* 215(w)* 140(h)mm
	ACCESSORIES	Output line : 3pcs Product use instructions: 1pc power cord : 1pc
	Matching	USB Interface, Communication Software

- 3、 direction for use
- 3.1 The switch knob on the panel of the position and function

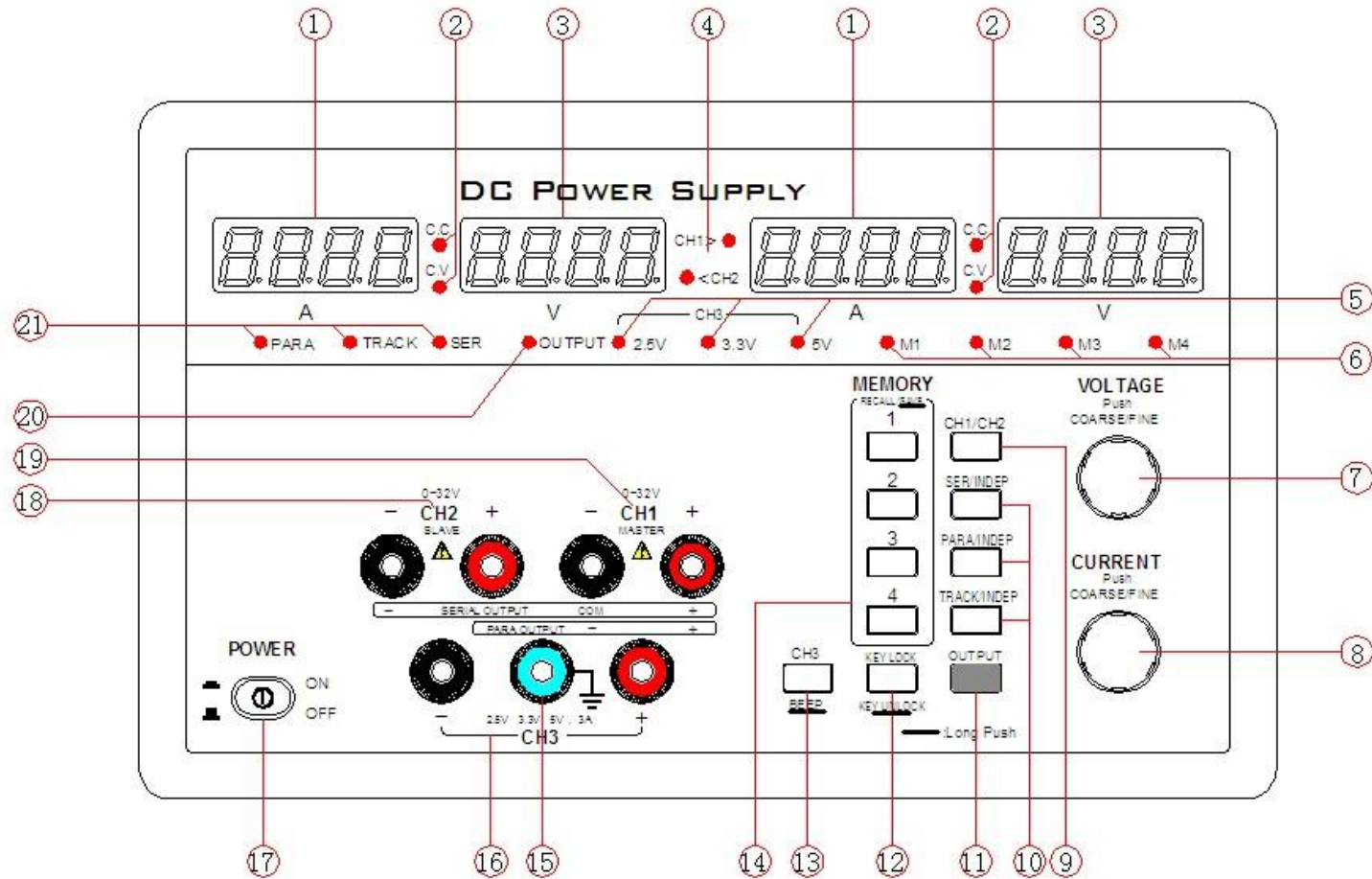

FIG1. Front panel figure

3. 1. 1 Front Panel introduction

- (1) Indicates the output current
- (2) Current and Constant status instructions
- (3) Indicates the output voltage
- (4) Working channel indicator
- (5) CH3 output state indicator
- (6) 4 Group output parameter storage instructions
- (7) Voltage adjust selection key
- (8) Current adjust selection key
- (9) Working channel choose
- (10) Working mode choose
- (11) Output control key
- (12) A key for Panel function lock
- (13) CH3 working voltage choose /turn on or turn off buzzer
- (14) Group 4 output parameters to store and select
- (15) Grounding (earth) terminals
- (16) 3 Channel output terminals
- (17) Power switch
- (18) 2 Channel output terminals
- (19) 1 Channel output terminals
- (20) The output state indicator
- (21) working mode indicator

3. 1. 2 Rear Panel introduction

- (22) USB interface
- (23) Cooling fan
- (24) Working voltage choice turn the switch

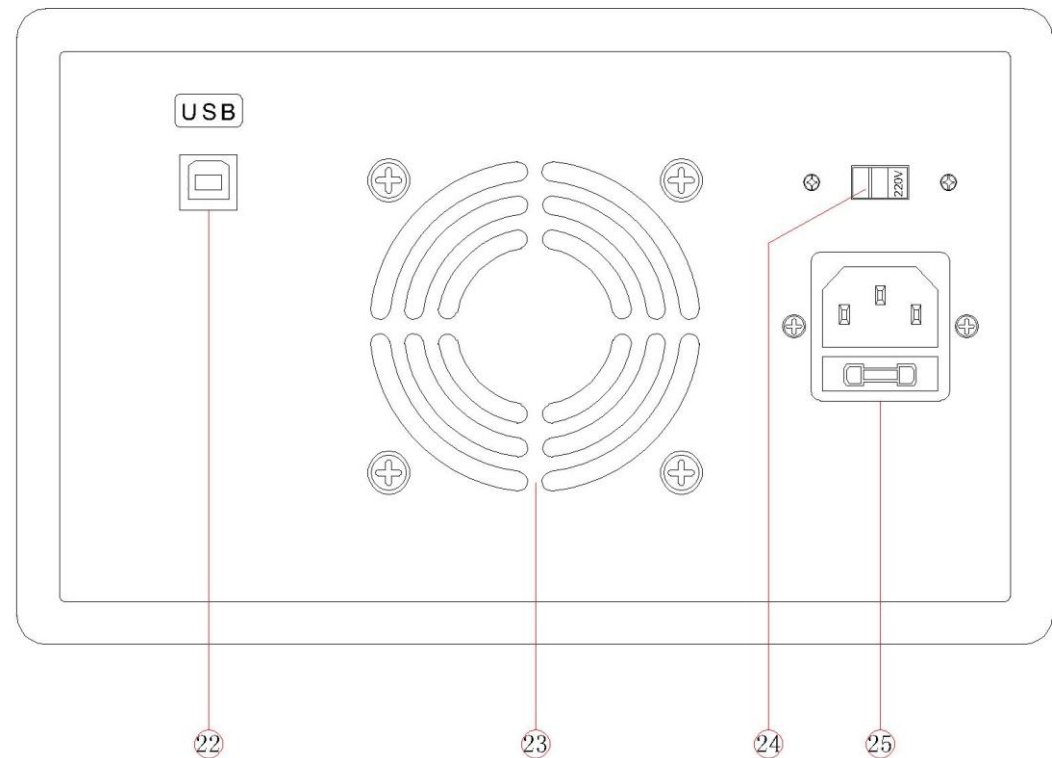

(25) Power supply socket and fuse holder

3.2 Operation Instruction

3.2.1 Front Panel Operation Instruction

Panel button that function:

- ✧ M1 M2 M3 M4: Preset storage parameters selection key;
- ✧ CH1 CH2: Channel selection key
- ✧ CH3: The third way output voltage select key, can choose 2.5V 、 3.3V 、 5V voltage output
- ✧ TRACK: Series select key
- ✧ PARA/INDEP: Parallel select key
- ✧ SER/INDEP: Tracking select key
- ✧ OUTPUT: Output shut off key, You can cut off output , and need not use the power switch;
- ✧ LOCK key: Easy lock all keys to the panel and all the works will not be external influence;
- ✧ VOLTAGECURRENT :Voltage/current adjust digital coding switch, effectively avoid the noise of the potentiometer, to make the output more stable and reliable。

3.2.2 Operation Instruction

This series of power supplies with output parameter storage group 16 functions in use can be divided into normal use, pre-storage to use both cases, normal use, Refer to the following steps:

CH1/CH2 Independent mode:

- (1) Confirm the indicator light on panel PARA SERIAL TRACK closed
- (2) Connects the load to the front panel terminals, CH1+/-, CH2+/-。
- (3) Set CH1 output voltage and current。 Press CH1 switch (CH1 indicator lamp light) Adjust voltage and current knob. Low speed rotating work in fine tuning mode, the high speed rotating work in the thick mode. Press the knob corresponding digital tube twinkle at this time can be a corresponding numerical adjustment。

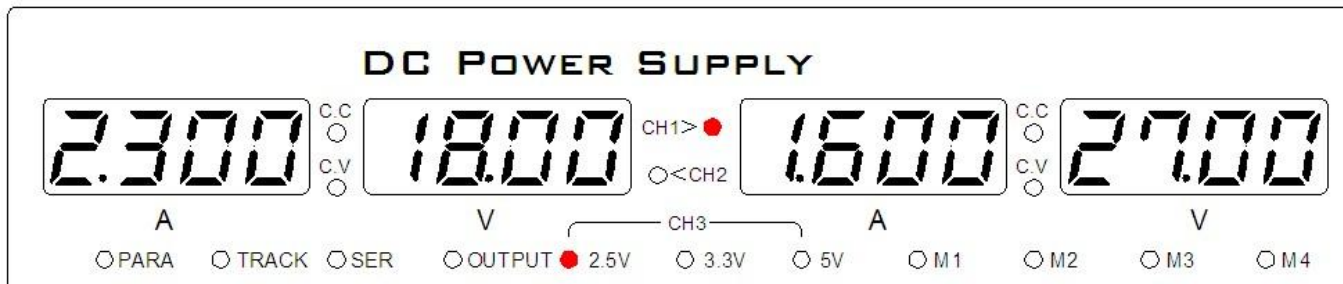

(4) CH2 Repeat the above set.

(5) Start OUTPUT, press the OUTPUT key indicator light and displays CV/CC mode.

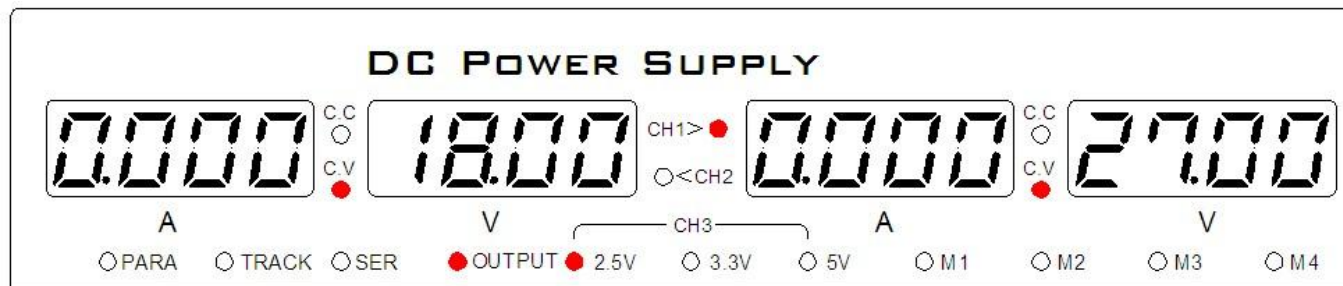

✧ CH3Independent mode:

CH3 no series/parallel mode, CH3 output is not subject to the influence of CH1 and CH2 mode

(1) Connects the load to the front panel terminals ,CH3+/-.

(2) Choose the output voltage

Press the CH3 key panel voltage output corresponding indicator lamp light, this time the voltage to be automatic output.

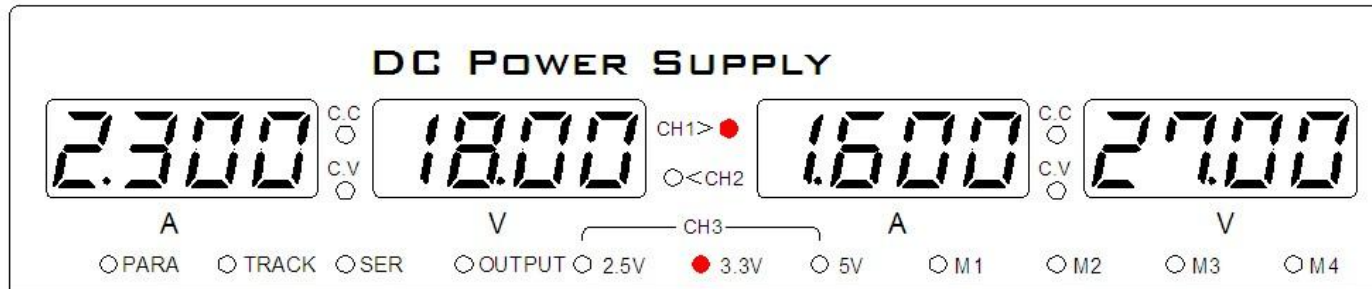

CV→CC When the output current value more than 3 A, CH3 lights flashing, CH3 operation mode from the constant pressure source into constant current source.

✧ CH1/CH2 Tracking mode:

(1) press SER/INDEP key ,enter tracking mode, SERIAL Indicator lamp light.

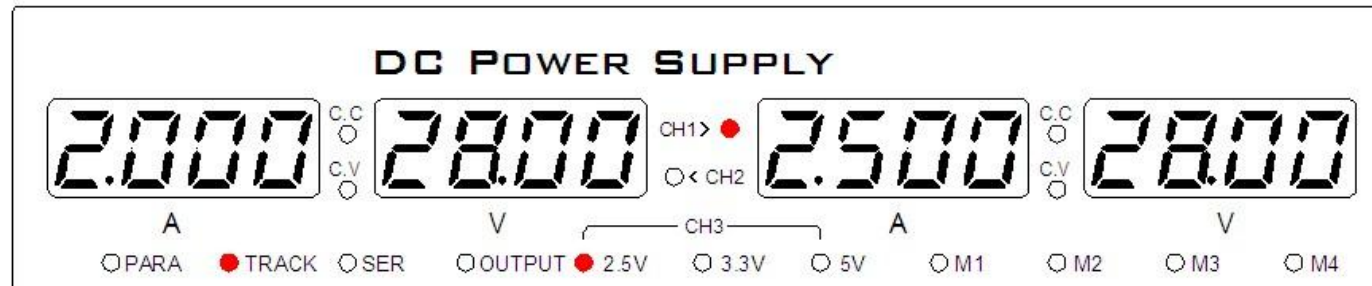

- (2) Connects the load to the front panel terminals, CH1+&CH2- (A group of power).
- (3) Choose CH1 channel adjust voltage current, CH2 channel voltage followed CH1 channel , this time working voltage is the sum of two channels.
- (4) Start OUTPUT, press the OUTPUT key. OUTPUT indicator light lights and shows CV/CC mode.

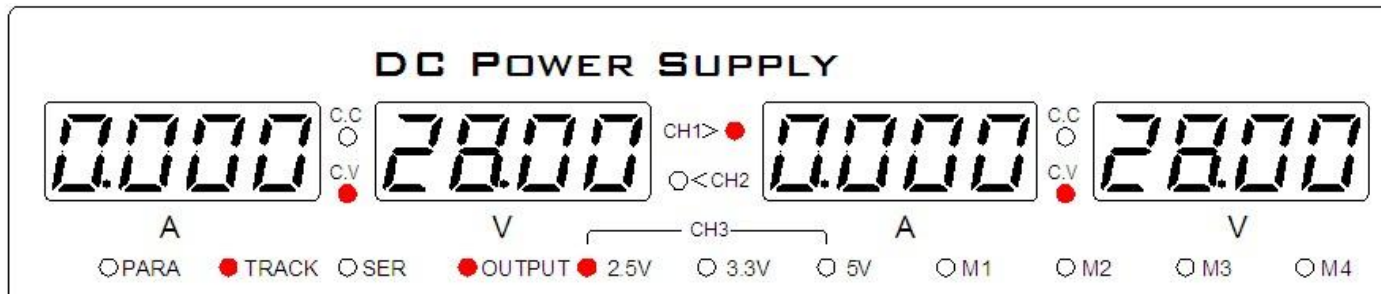

◇ CH1/CH2 mode in series :

(1) Press TRACE key enter the mode in series,TRACE indicator light lights.

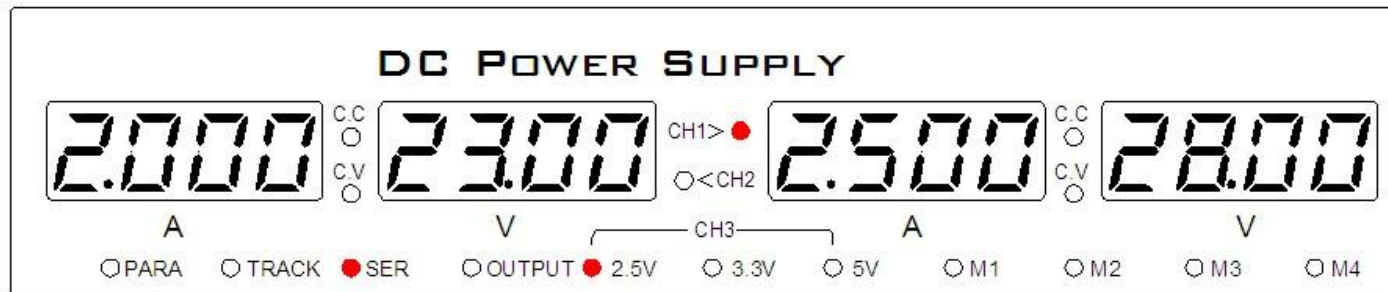

(2) Connects the load to the front panel terminals, CH1+&CH2- (A group of power).

(3) Press CH1/CH2 to choose channel, Adjust voltage current, This time working voltage is the sum of two channels

(4) Start OUTPUT, press the OUTPUT key. OUTPUT indicator light lights and shows CV/CC mode.

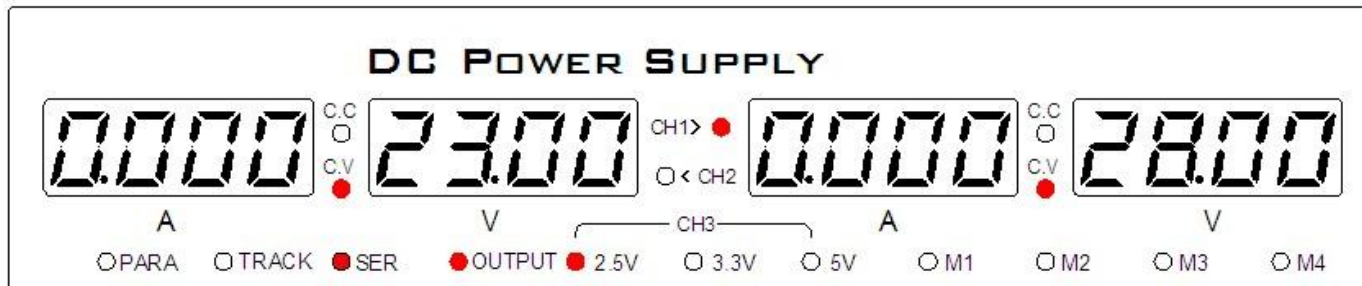

◇ CH1/CH2 mode in parallel :

(1) Press PARA/INDEP key enter mode in parallel, PARA indicator light lights.

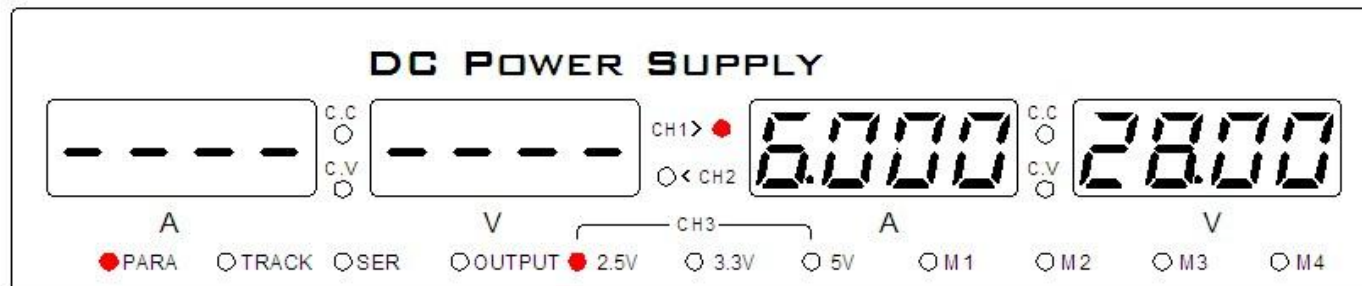

(2) Connects the load to the front panel terminals, CH1+/-, CH2+/- (A group of power).

(3) Choose CH1 channel adjust voltage current, CH2 channel voltage followed CH1 channel, this time working voltage is the sum of two channels.

(4) Start OUTPUT, press the OUTPUT key. OUTPUT indicator light lights and shows CV/CC mode.

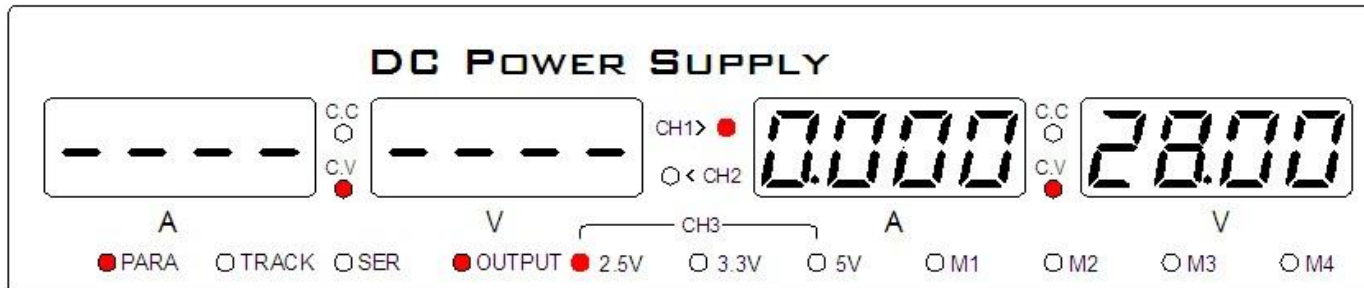

✧ Save/exhaled Settings:

Preinstall storage maximum 16 groupe output data preinstall, with M1 output parameters as an example, the operation procedure is as follows:

- (1) Storage operation : Press CH1/CH2 Choose storage channel, Press M1 for a long time ,you could store the current channel data into M1, When you hear the voice from the buzzer and see the M1 indicator light lights, Storage success.

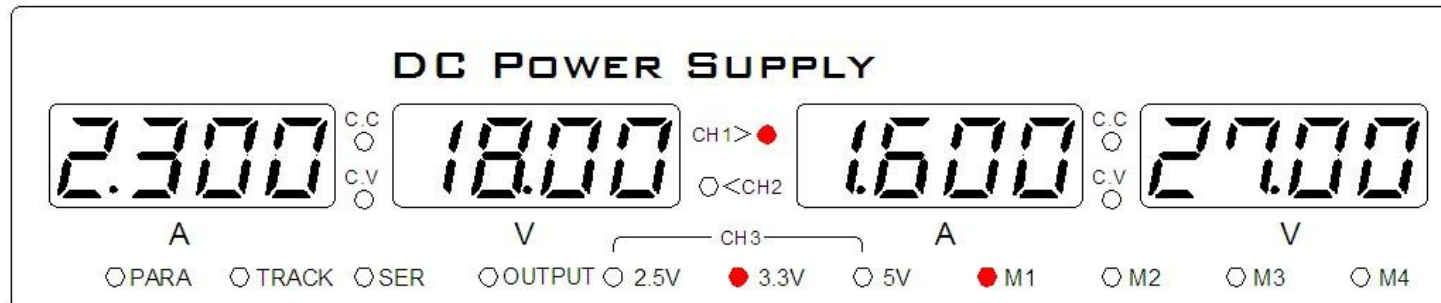

- (2) The success of the other group storage preset storage method and the same M1;
- (3) Retrieved operation: Press CH1/CH2 Choose storage channel, Press M1, Display M1 stored parameters, Press OUTPUT key, According to predetermined status output.

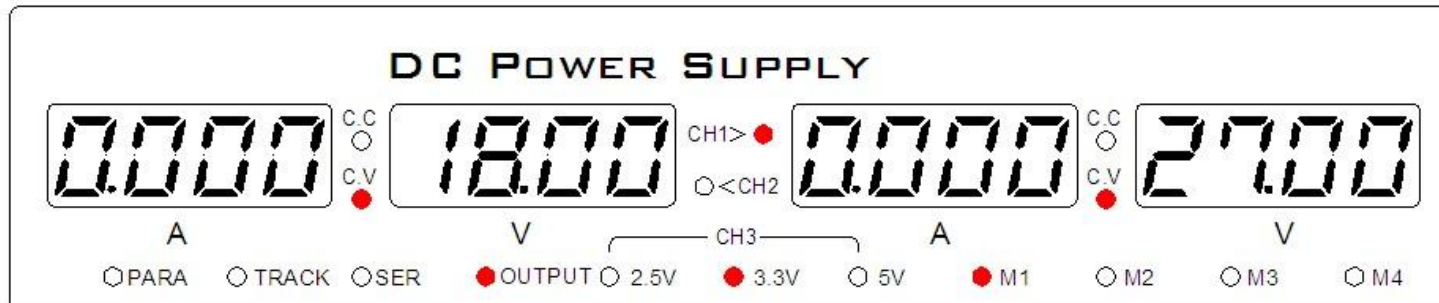

✧ Turn on or turn off the buzzer:
Press CH3 for a long time, It will turn on or turn off the buzzer.

Panel button lock:

The use of panel keypad lock is on, press the keyboard key lock (LOCK) 2 second or more, digital display "-Loc", said keyboard panel has been locked, the keyboard is locked, the Operation panel is displayed when "-Loc" prompt, all keys are not working, unlock long again by the button, you can return to normal status.

4. ATTENTION

- 4.1 The power supply features over-current protection with sound, when the output short circuit, the circuit protection will be activated only when a short circuit when troubleshooting to restore output.
- 4.2 Maintenance of power supply, the input power must be disconnected by repair professionals
- 4.3 Machine after use, please be ventilated dry place, not long-term, should unplug the power plug
- 4.4 Belong to high-power instrument of the power supply, at full capacity, therefore they should pay attention to the use of ventilation and cooling power, and power radiator shell and a higher temperature, please note that hand-to-avoid
- 4.5 Three core power cord the protective earthing grounding terminal must be reliable to ensure that the use of safety

4.6 When the power to place too much time re-use, pre-election power 15 - 20 minutes and be stable before equipment put into use

5. MAINTENANCE

The apparatus should be used under normal working conditions, are not allowed in the sunlight exposure, a strong vibration and occasions with the use of corrosive gases.

5.1 Fuse replacement

If the fuse burned, the equipment will not be able to work. Fuse will not open normally, unless the failure of circuits. Please check before replacing fuses may cause burning fuse circuit, and then replace the fuse. Fuse replacement, please use the original specifications in line with the fuse

5.2 Clening

When cleaning the instrument, use neutral detergent Baptist has a soft cloth and water. Do not spray detergent on the surface of the apparatus, there is probably because of detergent into the internal chassis damage. Do not use with gasoline, benzene, toluene, xylene, acetone and other chemical substances or similar solvent. Do not use abrasive cleaning products such as the apparatus

6. ACCESSORIES

Product use instructions	1
Power cord	1
Output Line:	3
Product certification	1
Matching: USB Interface, Communication Software	