



Eddy currents: Contactless measurement of electrical resistivity

Yaakov Kraftmakher

Citation: *Am. J. Phys.* **68**, 375 (2000); doi: 10.1119/1.19440

View online: <http://dx.doi.org/10.1119/1.19440>

View Table of Contents: <http://ajp.aapt.org/resource/1/AJPIAS/v68/i4>

Published by the [American Association of Physics Teachers](#)

Additional information on *Am. J. Phys.*

Journal Homepage: <http://ajp.aapt.org/>

Journal Information: http://ajp.aapt.org/about/about_the_journal

Top downloads: http://ajp.aapt.org/most_downloaded

Information for Authors: <http://ajp.dickinson.edu/Contributors/contGenInfo.html>

Eddy currents: Contactless measurement of electrical resistivity

Yaakov Kraftmakher

Department of Physics, Bar-Ilan University, Ramat-Gan 52900, Israel

(Received 24 November 1998; accepted 15 September 1999)

A simple and inexpensive student experiment is described, consisting of determination of the effective magnetic susceptibility of a cylindrical conductor in an axial ac magnetic field and contactless measurement of electrical resistivity. The experiment shows an important application of eddy currents. © 2000 American Association of Physics Teachers.

I. INTRODUCTION

Eddy currents induced in a conductor by an external ac magnetic field present an important topic in the course of electricity and magnetism and have many applications. Eddy currents cause losses in transformers and make it possible to levitate a conducting sample. They create a torque in motors employing rotating magnetic fields and reveal metallic objects such as weapons or mines. An important application of eddy currents is induction heating. Eddy currents are widely used for contactless measurements of electrical resistivity. The latter is the subject of a student experiment described below. The concept of the effective magnetic susceptibility of a conductor,¹ $\chi = \chi' + i\chi''$, is very useful in this respect. The effective magnetic susceptibility depends on eddy currents in a sample and has no relation to usual magnetic properties. It depends on the frequency of the ac magnetic field, electrical resistivity, and the shape of the sample. The effective magnetic susceptibility is a complex quantity because there is a phase shift between the electrical field induced by the ac magnetic field and eddy currents in the sample.

Many classroom demonstrations²⁻⁷ and laboratory experiments⁸⁻¹⁸ concerning eddy currents have been published. An experiment described by MacDougall⁸ consists of two parts, the magnetic shielding by a conducting sheet and distribution of current flowing through a wire bundle. Goselin *et al.*⁹ measured the frequency-dependent impedance of a round copper wire. A lock-in amplifier measured the real and imaginary parts of the impedance. Wiederick and Gauthier¹⁰ have described a simple method for determining the frequency dependence of the skin depth in a conductor. In an experiment reported by Ziółkowska and Szydłowski,¹¹ conducting tubes of different wall thickness were placed coaxially between a solenoid and a detecting coil; one then measures the amplitude and phase of the voltage induced in the detecting coil.

A determination of the effective magnetic susceptibility of a conducting rod by a differential transformer has been described by Juri *et al.*¹² Using a compensation circuit with a lock-in amplifier as the null detector, they measured the real and imaginary parts of the susceptibility versus the frequency of the magnetic field. To fit the experimental data to the theoretical curves, the data were shifted along the X axis by adjusting one parameter, the electrical resistivity of the sample. The authors recommended this procedure as a method for contactless determination of electrical resistivity. Wiederick *et al.*¹³ have presented a simple model of magnetic braking in a metal strip and confirmed it by experimental tests. Marcuso *et al.*¹⁴ performed an experiment on magnetic drag and compared the data with computer simulations. Edgar and Quilty¹⁵ reported on a mutual inductance apparatus

for measuring magnetic susceptibility and electrical resistivity. MacLatchy *et al.*¹⁶ have described a quantitative braking experiment. Cadwell¹⁷ has presented an analysis of the motion of a conducting plate as it passes through a magnetic field. The magnetic damping was studied by means of an airtrack and a motion detector. Recently, Hahn *et al.*¹⁸ determined the damping of a magnet oscillating inside a conducting tube.

Some comments should be made concerning the experiment reported by Juri *et al.*¹² First, the effective magnetic susceptibility of a conductor is available using a much simpler setup consisting of an oscillator, a differential transformer, and an oscilloscope. Both parts of the susceptibility are seen from the shape of the Lissajous pattern on the oscilloscope's screen. Second, if a lock-in amplifier is involved in the measurements, there is no need for a compensation of the output voltage of the differential transformer. After proper tuning, the lock-in amplifier that measures this voltage immediately provides dc voltages proportional to the real and imaginary parts of the susceptibility. Lastly, the electrical resistivity of a cylindrical sample is available from a single measurement based on determination of the phase angle of the effective magnetic susceptibility, instead of the procedure recommended by Juri *et al.*¹² As will be shown below, this phase angle depends on the radius and resistivity of the sample and on the frequency of the magnetic field.

A simple and inexpensive student experiment consisting of determination of the effective magnetic susceptibility and of contactless measurement of electrical resistivity is described below. In Sec. II, the theoretical expressions are presented which fit the effective magnetic susceptibility of a cylindrical conductor in an axial ac magnetic field to the frequency of the field and the radius and electrical resistivity of the conductor. Methods to determine the complex susceptibility are described. A simple and inexpensive setup is employed in the student experiment. The results of the experiment are the real and imaginary parts of the effective susceptibility as functions of the quantity Aa^2f/ρ , where A is a numerical constant, f is the frequency of the magnetic field, and a and ρ are the radius and electrical resistivity of the sample. The second part of the experiment is described in Sec. III. It presents contactless measurements of electrical resistivity based on the effective magnetic susceptibility. Lastly, in Sec. IV, an optional extension of the experiment is described allowing a direct digital readout of the resistivity.

II. DETERMINATION OF THE EFFECTIVE MAGNETIC SUSCEPTIBILITY

When a conductor is positioned in an external ac magnetic field, eddy currents appear in it. This leads to changes in the

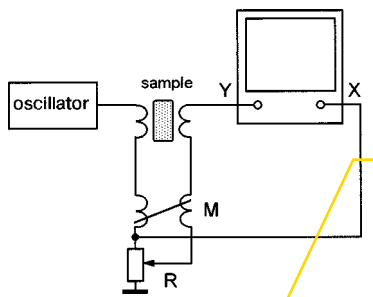

Fig. 1. Hartshorn bridge for determination of magnetic susceptibility

Esta ecuación está MAL y no se corresponde con la aproximación polinómica de (4). La correcta se puede ver en la referencia [19]

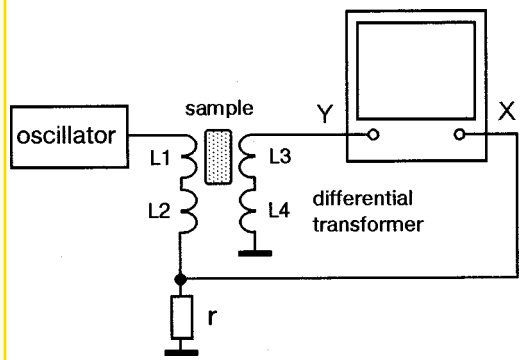

Fig. 2. Simplest setup for determining magnetic susceptibility.

magnetic field inside the conductor. According to Landau and Lifshitz,¹ the magnetization M per unit length of a cylindrical conductor of a radius a in an axial ac magnetic field H is

$$M = \pi a^2 \chi H. \quad (1)$$

The effective magnetic susceptibility χ of the conductor has been deduced to be

$$\chi = \chi' + i\chi'' = 2J_1(ka)/kaJ_0(ka) - 1. \quad (2)$$

Here J_0 and J_1 are Bessel functions of the first kind, $k = (1+i)/\delta$, $\delta = (2\rho/\mu_0\omega)^{1/2}$ is the skin depth, ρ is the electrical resistivity of the conductor, $\mu_0 = 4\pi \times 10^{-7}$ T.m.A⁻¹ is the permeability of free space, and $\omega = 2\pi f$ is the angular frequency of the magnetic field. As is seen from the above equation, the susceptibility is a complex quantity that depends only on ka , i.e., on the ratio a/δ . Both χ' and χ'' are negative. The goal of the experiment is to determine this dependence and to compare it with theory. It is useful to introduce a new variable, $X = a^2/\delta^2$. From the above definition of the skin depth,

$$X = 4\pi^2 \times 10^{-7} a^2 f / \rho = A a^2 f / \rho, \quad (3)$$

where $A = 3.95 \times 10^{-6}$.

Using numerical values of the Bessel functions, one can evaluate the effective magnetic susceptibility. This has been done by Chambers and Park.¹⁹ They have tabulated both parts of the susceptibility versus X . The authors expressed the susceptibility through Bessel functions J_2 and J_0 , but their relation is equivalent to Eq. (2). In the range $1 < X < 10$, the calculated absolute values of χ' and χ'' can be approximated by polynomials

$$\chi' = -0.088 + 0.1503X + 0.01566X^2 - 0.00737X^3 + 7.755 \times 10^{-4}X^4 - 2.678 \times 10^{-5}X^5, \quad (4a)$$

$$\chi'' = -0.048 + 0.378X - 0.12207X^2 + 0.017973X^3 - 0.0012777X^4 + 3.542 \times 10^{-5}X^5. \quad (4b)$$

The polynomials allow one to compare experimental results with the theory. The authors¹⁹ have described an experimental setup for measurements of the effective magnetic susceptibility by the mutual inductance method. A convenient compensation circuit, the so-called Hartshorn bridge, was used (Fig. 1). An oscillator feeds the primary windings of two mutual inductance coils. The secondaries are connected in opposition. The potentiometer R is set at zero. Without a sample, the variable mutual inductance M is adjusted to balance the voltage induced in the secondary winding of the main coil. The output voltage thus becomes zero. After a

conducting sample is put inside the main coil, an output voltage appears due to eddy currents in the sample. Because of the complex nature of the effective magnetic susceptibility of the sample, adjustment of the variable mutual inductance M and of the potentiometer R are necessary to balance the bridge. The two parts of the effective magnetic susceptibility, χ' and χ'' , are proportional to $\omega\Delta M$ and R , respectively, where ω is the angular frequency of the current feeding the primary windings, and ΔM is the change in the mutual inductance necessary to compensate the effect of eddy currents in the sample.

Nowadays, the effective magnetic susceptibility can be determined using a differential transformer and a lock-in amplifier. The voltage induced in a coil by eddy currents in the sample is small in comparison to the main voltage induced by the current creating the ac magnetic field. A differential transformer consisting of two similar mutual inductance coils serves to cancel this main voltage. Without a sample, the output voltage of the transformer is zero. The phase of the output voltage that appears after a conducting sample is put inside one coil of the transformer thus depends on the phase angle of the effective magnetic susceptibility. When a two-channel lock-in amplifier measures the output voltage of the differential transformer, one immediately obtains dc voltages proportional to the two parts of the susceptibility. For this purpose, one has to use a reference voltage for the amplifier, whose phase coincides with that of the current passing through the primary windings of the transformer. Under such conditions, two dc output voltages from the lock-in amplifier are proportional to χ' and χ'' . With a single lock-in amplifier, one determines χ' and χ'' in turn. This is possible due to a calibrated phase shifter incorporated in the amplifier. The Hartshorn bridge or a lock-in amplifier are the best tools to determine the effective magnetic susceptibility. However, the equipment necessary to assemble the Hartshorn bridge includes a variable mutual inductance, which is rarely available for student laboratories, as well as a lock-in amplifier. An alternative approach is described below.

A differential transformer is employed in the measurements. The Helmholtz coils $L1$ and $L2$ form the primaries of the transformer and create a homogeneous magnetic field (Fig. 2). They are about 14 cm in diameter, each containing 320 turns. A low-frequency oscillator feeds the coils. An important requirement is a good waveform for the feeding current, with a small harmonic content. A resistor $r = 10 \Omega$ connected in series with the Helmholtz coils provides a voltage U_x (for the X -input of an oscilloscope) that is proportional to the current passing through the coils, i.e., to the ac

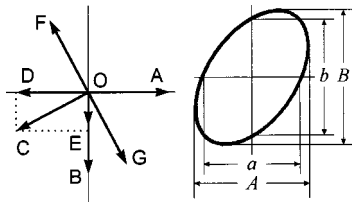

Fig. 3. Vector diagram of the circuit and determination of the phase angle from the Lissajous figure.

magnetic field. Two secondaries $L3$ and $L4$ are connected in opposition, so that without a sample the output voltage of the transformer is zero. The secondaries are 2 cm in diameter and 2 cm long, each containing 2500 turns. The necessary number of turns depends on the magnetic field and on the radius of the samples. Too many turns are undesirable because of the inherent capacitance of the coils. To obtain a stronger signal, it is better to use thicker samples, up to 1.5–2 cm in diameter. In our case, a copper sample is 1 cm in diameter and 10 cm long.

The output voltage of the transformer is fed to the Y -input of the oscilloscope. The secondaries are fixed on a common base whose position between the Helmholtz coils can be adjusted slightly. Since the magnetic field is somewhat inhomogeneous, such adjustment serves to finely balance the transformer in the absence of the sample. An additional coil connected in series with the secondaries and properly placed near the Helmholtz coils provides another possibility for such balancing. A small quadrature component in the output voltage also may appear. As a rule, it is small enough to be neglected. Otherwise, this component can be balanced by shunting one of the secondaries by a variable capacitor.

With a conducting sample inside one of the secondaries, an output voltage appears due to eddy currents in the sample. Its phase angle relative to the ac magnetic field, α , is complementary to the phase angle of the magnetic susceptibility, φ . It is obtainable from the shape of the Lissajous pattern. The features of the measuring circuit can be explained by means of a vector diagram (Fig. 3). The vector \mathbf{OA} represents the ac current in the primaries and the created magnetic field. The vector \mathbf{OB} is the emf created in the sample. The vector \mathbf{OC} shows the eddy currents and the magnetization of the sample. The magnetization contains two components, \mathbf{OD} and \mathbf{OE} . The first one is opposite to the external magnetic field and relates to χ' . The second one relates to χ'' . Its phase coincides with that of \mathbf{OB} , which means that the Joule heating of the sample is due to χ'' . The ac magnetization of the sample causes an additional emf in the corresponding secondary winding, represented by the vector \mathbf{OF} perpendicular to \mathbf{OC} . Since the main emf was compensated, just this voltage is fed to the Y -input of the oscilloscope. With opposite polarity of the output terminals, the output voltage should be represented by the vector $\mathbf{OG} = -\mathbf{OF}$. The phase shift between the voltages applied to the oscilloscope's inputs is obtainable from the well-known relation

$$\sin \alpha = \pm a/A = \pm b/B. \quad (5)$$

The output voltage of the transformer, U_y (for the Y -input of the oscilloscope), is also proportional to the amplitude and frequency of the current feeding the primary windings. The parts of the effective magnetic susceptibility, in arbitrary units, thus are given by

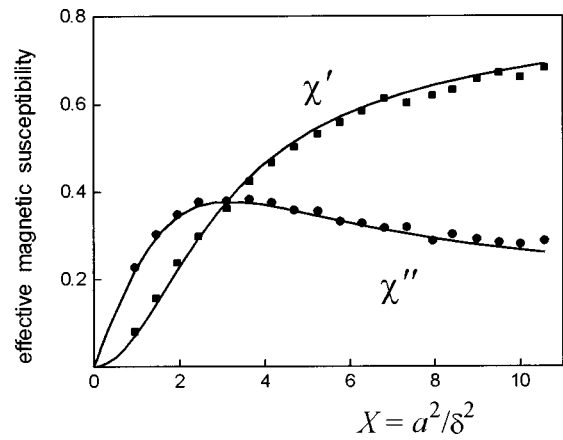

Fig. 4. Absolute values of the real and imaginary parts of effective magnetic susceptibility versus $X = a^2/\delta^2$.

$$\chi' = (U_y/fU_x) \sin \alpha, \quad (6a)$$

$$\chi'' = (U_y/fU_x) \cos \alpha, \quad (6b)$$

where U_y , U_x , and $\sin \alpha$ are available from the Lissajous pattern.

The resistivity of copper at room temperature, $1.7 \times 10^{-8} \Omega \cdot \text{m}$, was used to calculate the quantity $X = Aa^2f/\rho$ for the experimental points. To evaluate absolute values of χ' and χ'' , the experimental data were fit to the theoretical curves at the point of intersection of the two curves. According to Chambers and Park,¹⁹ the theoretical values at the intersection point are $\chi' = \chi'' = 0.377$. An appropriate scaling factor is determined from this fitting and then applied to the above equations, (6a) and (6b). After the fit, all the experimental data can be superposed on the theoretical curves available from Eqs. (4a) and (4b) (Fig. 4).

III. CONTACTLESS MEASUREMENT OF RESISTIVITY

In many cases, contactless measurements of resistivity have important advantages. By using samples in sealed ampoules, interaction between the samples and the environment is completely avoided. One particular use is to check on the quality of metals through their low-temperature resistivity. At liquid-helium temperatures, scattering of conduction electrons by impurities and physical imperfections of the crystal structure gives the main contribution to the resistivity of metals. The residual resistance ratio, the ratio of the resistivities at room and liquid helium temperatures, is a commonly accepted criterion of chemical purity and physical perfection of a metal. For pure metals, this ratio may amount to 10^4 – 10^5 and even more. At low temperatures, contactless measurements are preferable because the diameter of the samples can be made larger than the free path of electrons. Such measurements thus immediately provide correct values of the resistivity. Otherwise, one has to perform contact measurements on wire samples of various diameters and extrapolate the data to an infinite diameter.

Three main techniques are known for contactless measurements of electrical resistivity (see a review by Delaney and Pippard²⁰), namely, (i) determination of a torque applied to a sample due to a rotating magnetic field, (ii) observation of the decay of eddy currents in a sample after terminating an

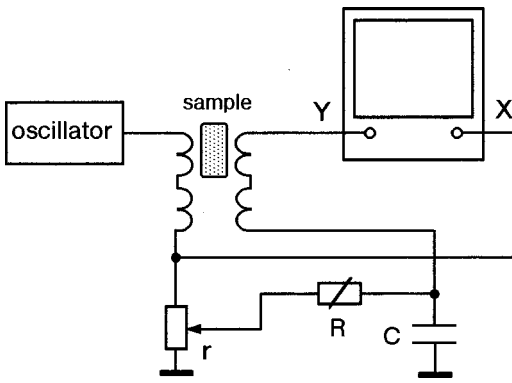

Fig. 5. Compensation circuit for contactless measurement of resistivity.

external magnetic field, and (iii) measurement of the effective magnetic susceptibility of cylindrical samples in an axial ac magnetic field. Such measurements are now widely employed (see, e.g., Ref. 21 and references therein).

From Eq. (3), the electrical resistivity of the sample is

$$\rho = A\alpha^2 f / X. \quad (7)$$

The simplest way to determine the resistivity is to express X through the phase angle of the effective magnetic susceptibility, $\varphi = \tan^{-1}(\chi''/\chi')$. Hereafter, we will use the phase angle $\alpha = \tan^{-1}(\chi'/\chi'')$ complementary to φ . The angle α is determined directly from the Lissajous pattern. Here X is a unique function of α and vice versa. This approach requires no determination of the absolute values of χ' and χ'' . The relation between X and $\tan \alpha = z$ may be approximated by a polynomial based on numerical values of χ' and χ'' . For $0.1 < z < 2.5$, a sufficient accuracy is achievable with the relation

$$X = -0.01 + 3.06z - 0.105z^2 + 0.167z^3. \quad (8)$$

The measurements of the resistivity thus reduce to the determination of the phase angle α . To evaluate the resistivity, one measures $z = \tan \alpha$ and then calculates X from Eq. (8). Then the resistivity is available from Eq. (7). A simple compensation circuit (Fig. 5) enhances the accuracy of the measurements. The same differential transformer is employed as before but now the output voltage is compensated by a circuit including a potentiometer r , a decade resistance box R , and a capacitor $C = 40$ nF. The voltage across the capacitor C is added to the output voltage of the differential transformer, and an oscilloscope serves as the null detector. The RC circuit provides the necessary phase angle of the compensation voltage while its amplitude is adjusted by the potentiometer r . To simplify the measurements, only the phase angle α is determined, which is sufficient to evaluate the sample's resistivity. The phase shift introduced by the RC circuit equals $\tan^{-1}(\omega RC)$. Hence $\tan \alpha = z = \omega RC$. The resistance r is much smaller than R , and its contribution is negligible. Only one calibrated variable resistor, R , is thus necessary, whereas the potentiometer r needs no calibration. Instead of the decade resistance box, one may use a simple variable resistor and measure its resistance by a multimeter every time after compensation.

Contactless measurements are most accurate in a definite frequency range depending upon the radius and electrical resistivity of the sample. Very low frequencies lead to a weak signal, whereas at too high frequencies the phase angle

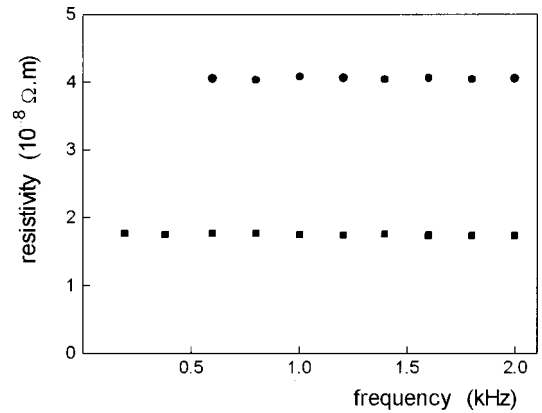

Fig. 6. Electrical resistivity at room temperature versus frequency of magnetic field: ■—copper, ●—aluminum alloy.

α is close to 90° . In both cases, the error in the resistivity may become unacceptable. In our case, the frequency of the magnetic field ranges from 0.2 to 2 kHz.

Two samples are used in the measurement: the same copper rod as before, and an aluminum-alloy rod. The results are presented versus the frequency of the magnetic field. Using the compensation circuit, the scatter of the data is of about 1% (Fig. 6). The resistivity of copper at room temperature was found to be $1.73 \times 10^{-8} \Omega \cdot m$. The resistivity of the aluminum alloy is $4.04 \times 10^{-8} \Omega \cdot m$. The independence of the results on the frequency confirms the validity of the method.

Measurements are performed also at liquid nitrogen temperature. A dewar filled with liquid nitrogen is positioned between the Helmholtz coils. The secondaries are immersed in the liquid. The frequency range is 0.1–1 kHz. Besides measurements of the resistivity of the two samples, the students observe the signal due to a high-temperature superconductor. In this case, the phase angle of the output voltage of the differential transformer cannot be distinguished from 90° , which means zero electrical resistivity.

To determine the effective magnetic susceptibility, one measures, in addition to the phase angle α , the output voltage of the differential transformer before compensation and the amplitude and frequency of the current passing through the Helmholtz coils. The values of χ' and χ'' , in arbitrary units, are then available from Eqs. (6a) and (6b).

IV. DIRECT READOUT OF THE RESISTIVITY

Here $X = a^2/\delta^2$ is the only quantity that governs the effective magnetic susceptibility of a cylindrical conductor in an axial ac magnetic field. For a given radius of the sample, it depends only on the ratio f/ρ . This suggests a possibility to express the resistivity through the frequency of the magnetic field and thus to immediately obtain the resistivity in digital form. Such a possibility has been already explored.²¹ The phase angle of the compensation voltage can be set beforehand to make the compensation possible only at a frequency of the magnetic field that, with a known decimal coefficient, equals the resistivity of the sample. According to Eq. (7), this phase angle must satisfy the relation $X = Aa^2/10^n$, where n is an integer. With such a phase angle, after compensation one obtains $\rho = 10^n f$, i.e., the resistivity numerically equals the frequency of the magnetic field. The necessary phase shift of

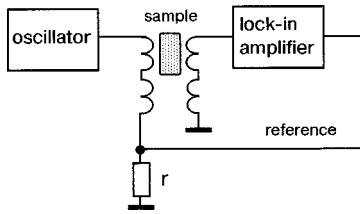

Fig. 7. Simplest setup to obtain digital readout of the resistivity.

the compensation voltage equals $\alpha = \tan^{-1} z$ and depends only upon the sample's radius. It is available from the fitting polynomial

$$z = -0.009 + 0.353X - 0.0093X^2 - 2.9 \times 10^{-5}X^3. \quad (9)$$

By choosing $n = -10$, for a sample of 1 cm in diameter one obtains $X = 0.987$, and $z = 0.33$. The corresponding phase angle is 18.3° . The resistivity of the sample ($\Omega \cdot \text{m}$) equals $10^{-10}f(\text{Hz})$. The resistivity range $10^{-8} - 10^{-7} \Omega \cdot \text{cm}$ thus corresponds to the frequency range 0.1–1 kHz. If $n = -11$, then $X = 9.87$, $z = 2.54$, and the proper phase angle is 68.5° . In this case, the same resistivity range corresponds to frequencies of 1 to 10 kHz.

The simplest method to obtain digital readout of the resistivity is to employ a lock-in amplifier (Fig. 7). The primary windings of a differential transformer are connected in series with a resistor r and fed by an oscillator of variable frequency. A lock-in amplifier measures the output voltage of the transformer. The voltage drop across the resistor r serves as a reference for the amplifier. The phase shifter in the amplifier is set at a phase angle complementary to α . This means that the dc output voltage of the amplifier becomes zero when the frequency of the current feeding the transformer numerically equals the resistivity of the sample. Before the measurements, it is necessary to check that the lock-in amplifier itself does not introduce additional phase shifts. If the input voltage and the reference are of the same phase, the dc output voltage must become zero when the phase shifter in the amplifier is set at 90° .

The resistivity of the copper sample was measured by means of a modern lock-in amplifier, Stanford Research Systems model SR830. This two-channel amplifier immediately provides the modulus of the input voltage and its phase angle relative to the reference. In our case, the reference is the voltage drop across the resistor connected in series with the primary windings of the differential transformer. After the sample is put inside the coil, one varies the frequency of the current feeding the transformer until the phase angle of the output voltage amounts to values calculated above. For both values of n , the results obtained are within $(1.70 \pm 0.04) \times 10^{-8} \Omega \cdot \text{m}$.

Another possibility²¹ is based on employment of an oscillator with auxiliary outputs providing voltages with the phase shifts 90° , 180° , and 270° relative to the main voltage. The amplitudes and phases of these voltages are independent of frequency. With such an oscillator, a compensation voltage is obtainable with any desired phase shift that does not depend on frequency and meets the requirements for the measurements. Probably, such voltages could be also generated by means of a computer.

V. SUMMARY

The student experiment described above shows an important application of eddy currents, the contactless measurements of electrical resistivity. The measurements are performed in a simple and straightforward manner. The determination of the effective magnetic susceptibility yields results that are in good agreement with the theory. The contactless measurement of electrical resistivity on bulk samples demonstrates the capabilities of a technique that may not be widely known. The experiment is inexpensive and could become a useful addition to student works in the field.

ACKNOWLEDGMENTS

The author thanks the referees for the criticism and useful suggestions. The support of the Ministry of Absorption of Israel is gratefully acknowledged.

¹L. D. Landau and E. M. Lifshitz, *Electrodynamics of Continuous Media* (Pergamon, Oxford, 1984).

²E. J. Churchill and J. D. Noble, "A demonstration of Lenz' law?" *Am. J. Phys.* **39**, 285–287 (1971).

³W. T. Doyle and R. Gibson, "Demonstration of eddy current forces," *Am. J. Phys.* **47**, 470–471 (1979).

⁴C. T. Young, "Electromagnetic wave propagation in aluminum," *Am. J. Phys.* **48**, 417–418 (1980).

⁵S. Y. Mak and K. Young, "Floating metal ring in an alternating magnetic field," *Am. J. Phys.* **54**, 808–811 (1986).

⁶B. S. Perkalskis and J. R. Freeman, "Extending Elihu Thomson's demonstration and Lenz's law," *Am. J. Phys.* **65**, 1022–1024 (1997).

⁷C. S. Schneider and J. P. Ertel, "A classroom jumping ring," *Am. J. Phys.* **66**, 686–692 (1998).

⁸J. W. MacDougall, "An experiment on skin effect," *Am. J. Phys.* **44**, 978–980 (1976).

⁹J. R. Gosselin, P. Rochon, and N. Gauthier, "Study of eddy currents in a cylindrical wire: An undergraduate laboratory experiment," *Am. J. Phys.* **50**, 440–443 (1982).

¹⁰H. D. Wiederick and N. Gauthier, "Frequency dependence of the skin depth in a metal cylinder," *Am. J. Phys.* **51**, 175–176 (1983).

¹¹E. A. Ziolkowska and H. Szydlowski, "Remarks on the skin effect experiment in an undergraduate laboratory," *Am. J. Phys.* **52**, 857 (1984).

¹²L. O. Juri, V. I. Bekeris, and R. G. Steinmann, "Skin depth and complex magnetic susceptibility: An experimental alternative approach," *Am. J. Phys.* **54**, 836–838 (1986).

¹³H. D. Wiederick, N. Gauthier, D. A. Campbell, and P. Rochon, "Magnetic braking: Simple theory and experiment," *Am. J. Phys.* **55**, 500–503 (1987).

¹⁴M. Marcuso, R. Gass, D. Jones, and C. Rowlett, "Magnetic drag in the quasi-static limit: Experimental data and analysis," *Am. J. Phys.* **59**, 1123–1129 (1991).

¹⁵A. Edgar and J. W. Quilty, "A mutual inductance apparatus for measuring magnetic susceptibility and electrical conductivity," *Am. J. Phys.* **61**, 943–946 (1993).

¹⁶C. S. MacLachy, P. Backman, and L. Bogan, "A quantitative braking experiment," *Am. J. Phys.* **61**, 1096–1101 (1993).

¹⁷L. H. Cadwell, "Magnetic damping: Analysis of an eddy current brake using an airtrack," *Am. J. Phys.* **64**, 917–923 (1996).

¹⁸K. D. Hahn, E. M. Johnson, A. Brokken, and S. Baldwin, "Eddy current damping of a magnet moving through a pipe," *Am. J. Phys.* **66**, 1066–1076 (1998).

¹⁹R. G. Chambers and J. G. Park, "Measurement of electrical resistivity by a mutual inductance method," *Br. J. Appl. Phys.* **12**, 507–510 (1961).

²⁰J. A. Delaney and A. B. Pippard, "Electrodeless methods for conductivity measurement in metals," *Rep. Prog. Phys.* **35**, 677–715 (1972).

²¹Y. Kraftmakher, "Measurement of electrical resistivity via the effective magnetic susceptibility," *Meas. Sci. Technol.* **2**, 253–256 (1991).